

# AlphaMAC

The avant-garde  
in fluid packaging





## THE AVANT-GARDE IN FLUID PACKAGING

Alphamac is the avant-garde in the design of machines for fluid packaging, an innovative approach and a different vision of the design and construction of extrusion and blow-moulding systems, which aims to anticipate customer needs to meet the demand of the present and the immediate future.

Alphamac is a new born in the industry, but with a strong DNA in the field of extrusion blow-moulding. The strength of Alphamac lies in the people, a highly specialized team with a complete and extensive knowledge of extrusion and blow-moulding technologies, raw materials and plastic packaging production processes.



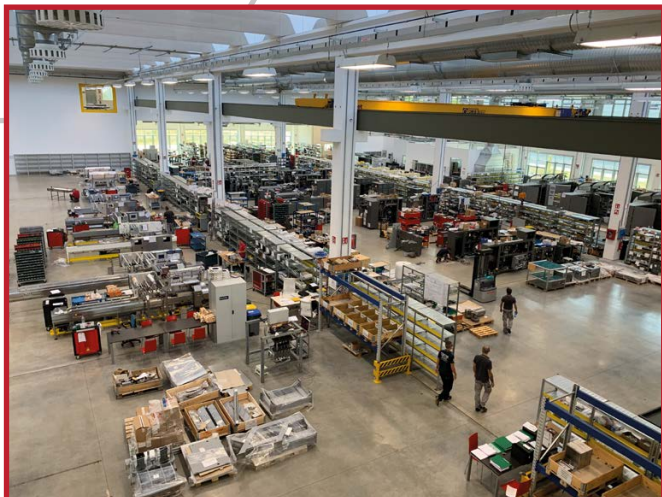

The experience in creating complete packaging lines for fluid products allows Alphamac to present itself to the market as a new player, but highly competent and competitive.

## A NEW INDUSTRIAL MODEL

Starting from the business model, Alphamac differs from existing industries. A streamlined structure which includes the highest value activities, internally preserving the company's know-how and coordinating a network of partners for the management of outsourced production activities. This industry model allows us to be extremely flexible and efficient, ensuring maximum competence in every phase of the process thanks to the collaboration of specialized companies in the management of no-core activities.

Our partners are focused on the world of automatic machines and the geographical proximity to Alphamac headquarters allows a constant cooperation and verification of operations.

- > FLEXIBILITY
- > EFFICIENCY
- > MAXIMUM COMPETENCE

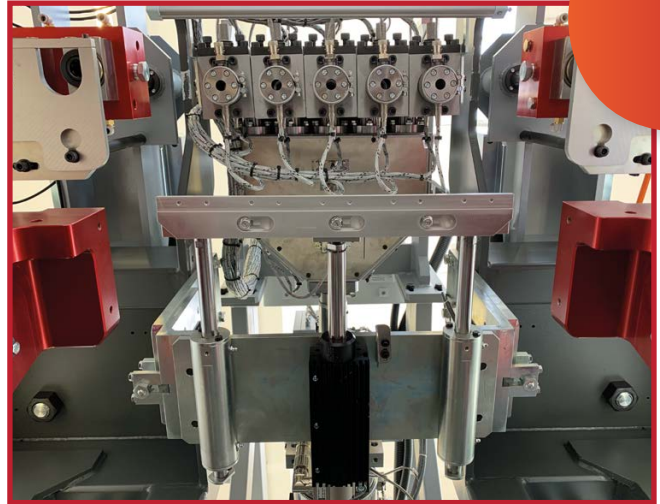
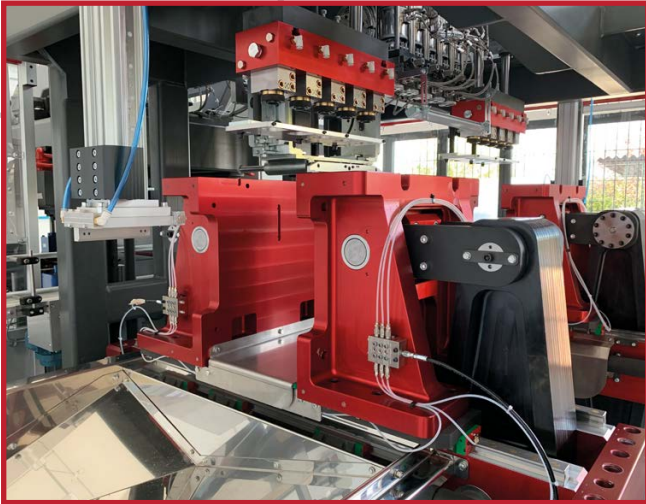

## THE TECHNOLOGICAL AVANT-GARDE OF ALPHAMAC

### SIMPLICITY AS A GOAL

Simple and robust mechanics, with solutions set to simplify maintenance, consisting of the minimum number of parts, all subjected to FEM at the time of design. Total absence of electrical cables and pipes that hinder maintenance and mould replacement operations.

### REDUCING SPACES

Small size of the footprint, with simple, inspectable and safe connections between the two parts of the machine.

### EASY HUMAN MACHINE INTERACTION

High definition touch interface, intuitive with icon dialogue, essential information for immediate availability and levels of access customized according to the operator's skills. Automatic optimization function to simplify process set-up.

# PACKAGING SOLUTIONS FOR FLUID

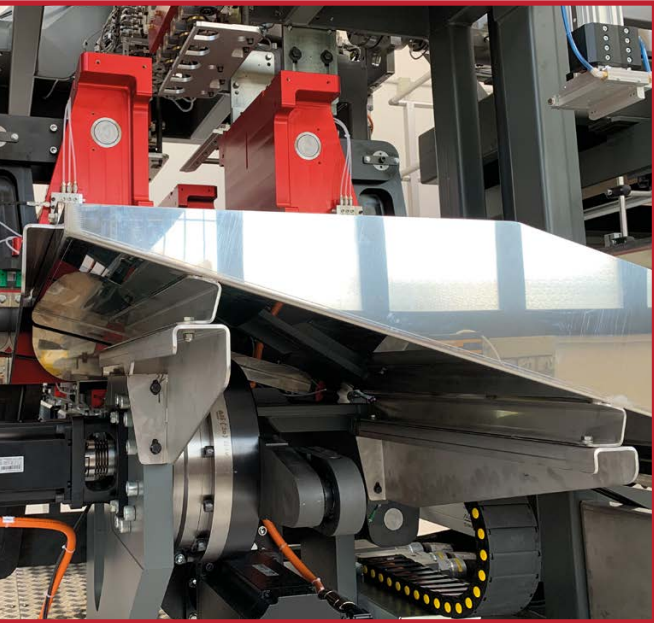

## THE CUTTING EDGE IN EXTRUSION

Cutting-edge technology for extrusion screws with high capacity for the use of recycled material and direct production waste material. Multi-cavity and multilayer extrusion heads with solutions for external control of weight levelling and quick colour change.

## COMPETENCE IN RAW MATERIALS

Established technology for the use of barrier materials for aggressive products and food long shelf-life products (Nylon, EVOH). Research and development for the extrusion of bio-materials and high competence on materials coming from post-consumer (PCR).

## MOTION SYSTEM

Motorizations with cutting-edge solutions, low energy consumption gear-boxes with automatic recovery of mechanical backlashes. Redundant control for mechanical units positions ("no crash"). Self-tuning devices to facilitate replacement in the event of a fault.



## MACHINE RANGE

 **ZERO**  
alphaMAC

Machine suitable to produce containers up to 5L volume size in single shuttle.  
Shuttle stroke 600 mm  
Clamping force 180 kN

 **SEICENTO**  
alphaMAC

Machine suitable to produce containers up to 5L volume size in double shuttle.  
Shuttle stroke 600 mm  
Clamping force 180 kN

 **MILLEDUE**  
alphaMAC

Machine suitable to produce containers up to 5L volume size.  
Shuttle stroke 1.200 mm  
Clamping force 450 kN

 **VENTI**  
alphaMAC

Machine suitable to produce jerry can from 10L to 25L volume size.  
Shuttle stroke 600 mm  
Clamping force 300 kN

# OX NOVECENTO

alphaMAC

Machine suitable to  
produce containers  
up to 5L volume size.  
Shuttle stroke 900 mm  
Clamping force 300 kN

# OX ASEPTA

alphaMAC

Machine suitable to  
produce containers  
up to 5L through  
sterile blowing process.  
Shuttle stroke 1.200 mm  
Clamping force 450 kN

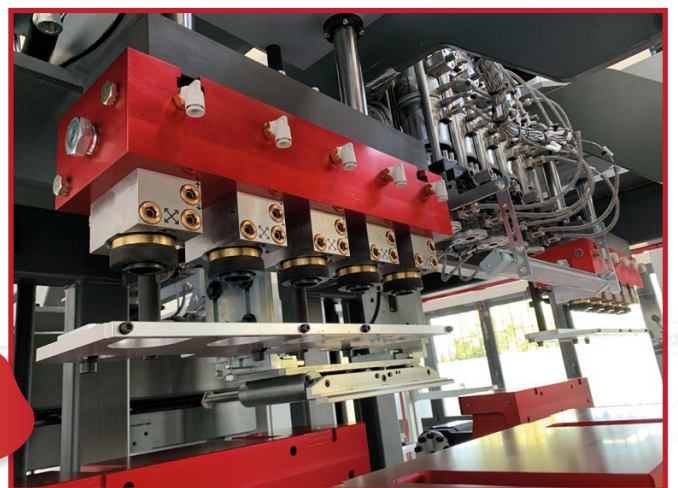

WWW.ALPHAMAC.IT

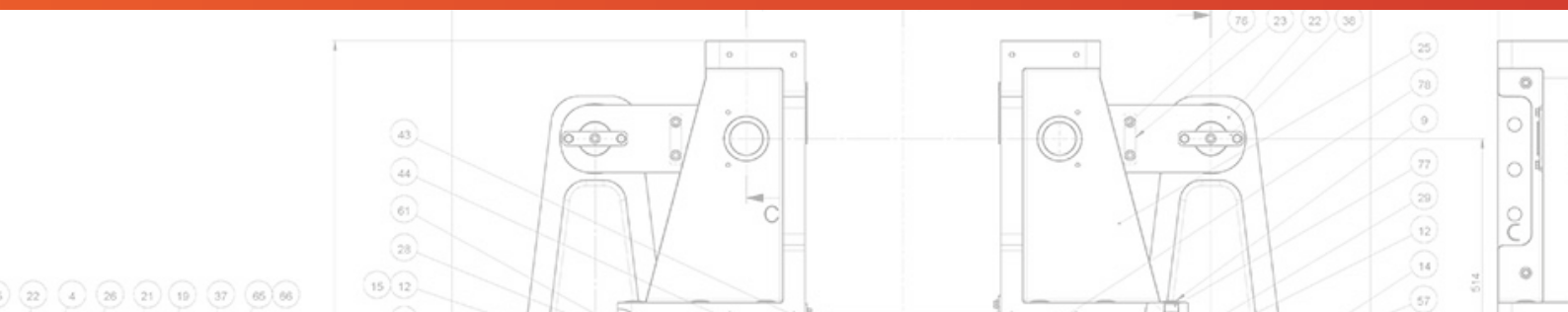

 alphaMAC

 Via Nobel, 20  
40064 Ozzano Dell'Emilia, Bologna, Italia

 +39 051 0185184  
 [info@alphamac.it](mailto:info@alphamac.it)

